

Lunghezza tubo	15 m
Pressione di lavoro	max 20 bar a 25°C (Aria) - max 10 bar a 70° C (Acqua)
Connessione ingresso	1/2" Maschio
Connessione uscita	1/2" Maschio x tubo + attacco rapido x NITO
Peso	19,3 Kg
Materiali costruttivi rullo e fiancate	AISI 304
Materiali costruttivi perno e giunto	AISI 303
Materiale molla principale	Acciaio al carbonio
Adatto all'utilizzo	Aria-Acqua

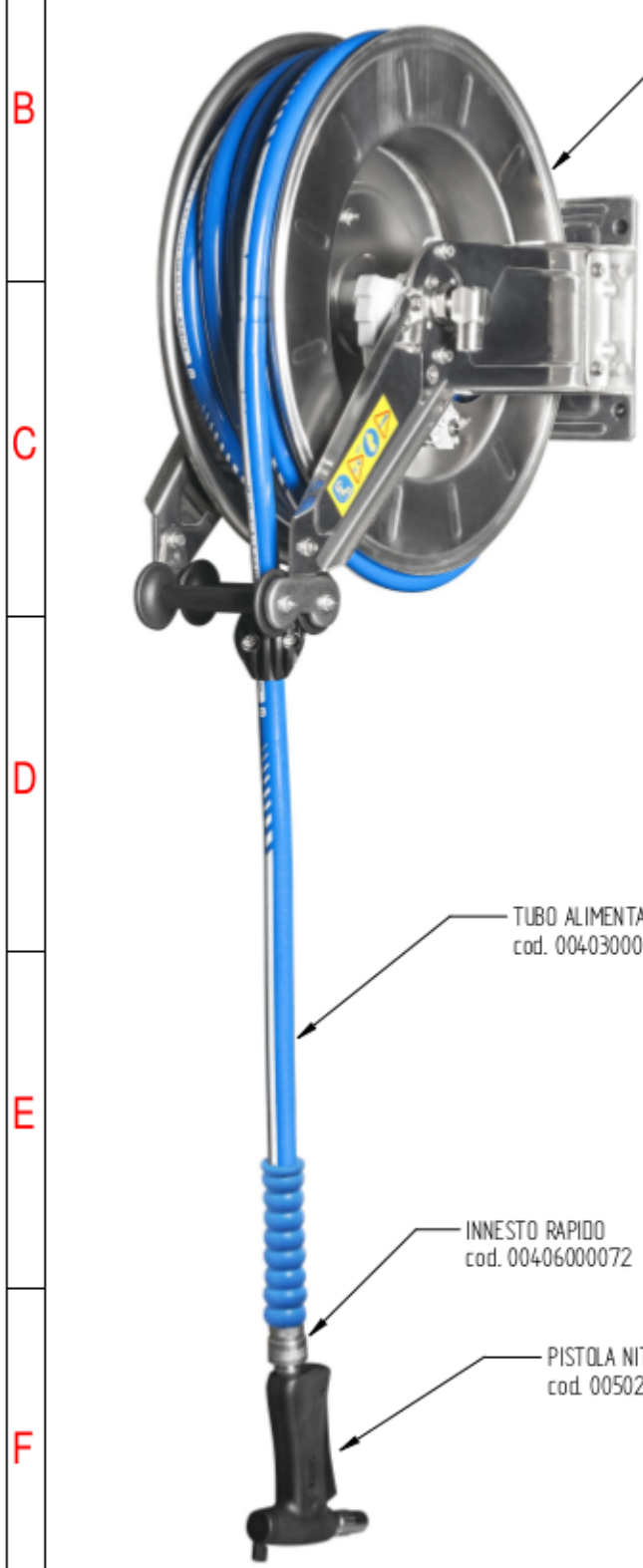

AVVOLGI TUBO AUTOMATICO
cod. 00803000057

TUBO ALIMENTARE 15m
cod. 00403000116

INNESTO RAPIDO
cod. 00406000072

PISTOLA NITO
cod. 00502000010

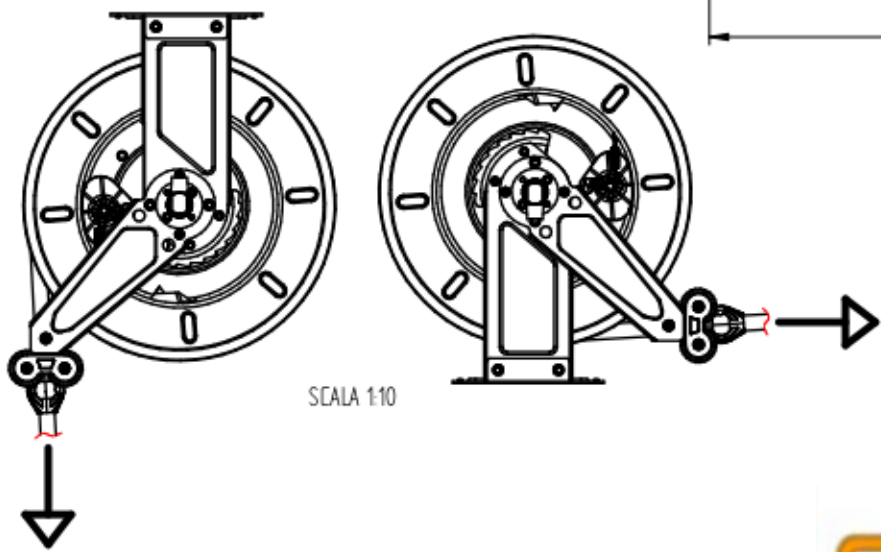

SCALA 1:10

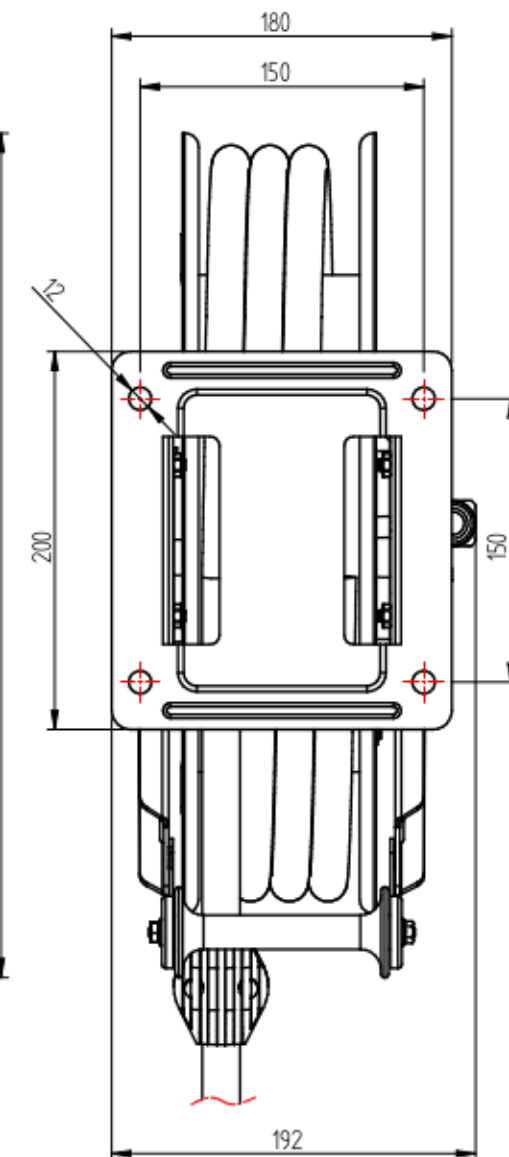
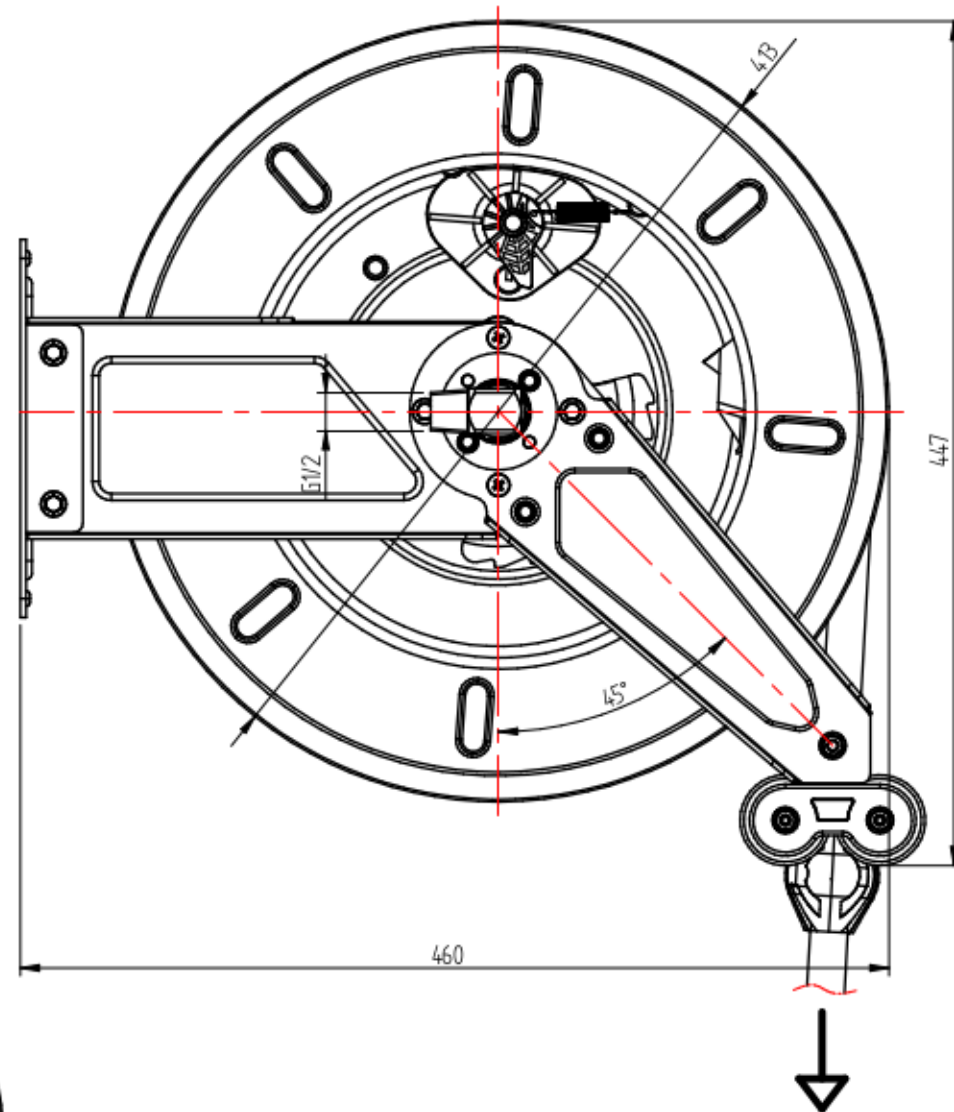

SHOP GROUP STORE

Shop Group S.r.l.
Via A. de Gasperi, 3
01033 Civita Castellana (VT)
Servizio assistenza clienti
Tel 0761/599396
email: info@shopgroup.it